



## R&M Group Packing and Shipping Conditions

R&M Group

# Table of Contents

1-9

1	Area of Application	13
2	Shipping Address	13
3	Warehouse R&M Goods Receipt Times	13
4	Shipping Documents	13
5	Test Documents and Certificates	14
6	Delivery Condition	14
7	Delivery Dimensions and Weights	15
8	Protection	15
9	Product Labeling	16
10	Collective Shipment	16
11	Packaging Material	17
12	Load Mounting	18
13	Separate Protection of Goods	18
14	Product-Specific Packaging	18
15	Regulation of Exceptions	18
16	Deviations	18
17	Contact Details	19

## 01 Definitions and Area of Application

"R&M Group" stands for Rheinhold & Mahla GmbH including its subsidiaries as a cooperate group. "R&M" stands for a company of the R&M Group that has placed the order. "Supplier" stands for the supplier with whom R&M has entered into an order.

The R&M Group Shipping and Packaging Conditions apply to all orders for goods. The Supplier is obliged to inform himself about the ultimate destination of the goods at the latest before delivery of the goods.

If product-specific packaging instructions exist, these shall also apply and shall have priority. The Supplier is obliged to inform about such product-specific packaging instructions at an early stage, at the latest before delivery of the goods.

## 02 Shipping Address

The Incoterm and place of delivery agreed between the parties shall apply. If no agreement on an Incoterm has been made, DAP (Incoterms 2022) shall apply to deliveries within the European Economic Area and FCA (Incoterms 2022) shall apply to deliveries worldwide (outside the European Economic Area or into the European Economic Area) with the place of delivery named in the order.

## 03 Warehouse R&M Goods Receipt Times

Goods receipt times of the Warehouse from R&M Germany is (except national holidays):

R&M Ship Technologies GmbH:

warehouse Neumünster, Oderstraße 49, 24539 Neumünster, Deutschland.

Loading time:

monday to friday: 07:00 – 13:00 Uhr

contact: Henning Schultz

warehouse Lemwerder, Ritzenbütteler Straße 47, 27809 Lemwerder, Deutschland.

Loading time:

monday to friday: 07:00 – 14:00 Uhr

contact: Mark Kaufmann

R&M MIT Services GmbH:

warehouse Glinde, c/o SGB Deutschland GmbH, Möllner Landstraße 41, Anfahrt über Sandweg 19, 21509 Glinde, Deutschland

loading time:

Monday to thursday: 09:00-15:00 Uhr

friday: 09:00-13:00 Uhr

contact: Michael Danowsky

phone: +49 40 238 329616!

## 04 Shipping Documents

Each shipment must be accompanied by the appropriate documents, to allow all necessary processing steps (if applicable import, export, processing of incoming and outgoing goods) to be carried out.

At a minimum, the following documents shall be provided, if applicable:

- Delivery note
- Invoice or pro forma invoice
- Certificate of origin
- Bill of lading (CMR, Carnet, B/L or AWB)
- Pictures of the shipment including the IPPC stamp

The freight must be accompanied by copies of the following documents:

- Delivery note
- Pro-forma invoice
- Export declaration (export)

Insofar as the original documents are required, they must be sent by a courier to R&M at the following address:

R&M Group  
Purchase/Logistic  
Schellerdamm 22-24  
21079 Hamburg/Germany

unless otherwise specified by R&M. When sending the documents by regular mail, the sender shall bear all risks in connection with a possible loss of these documents.

Unless otherwise agreed, a delivery bill must be attached to each shipment in a clearly visible manner.

## 05 Test documents and Certificates

The test documents and certificates named in the order must be sent to R&M immediately after dispatch.

## 06 Delivery Condition

The goods must be packed in such a way that they cannot be damaged or contaminated during transportation. R&M reserves the right to refuse acceptance of the shipment if there are discrepancies in the quantities or if the goods are damaged. Shipments not delivered in proper packaging will be returned at the Supplier's expense.

Shipments in one package must be of the same type. If this is not possible, the contents must be clearly marked on the packaging.

For each delivery, it must be ensured that the goods are secured with clamp closures and by lashing down and packed in tight-fitting packaging.

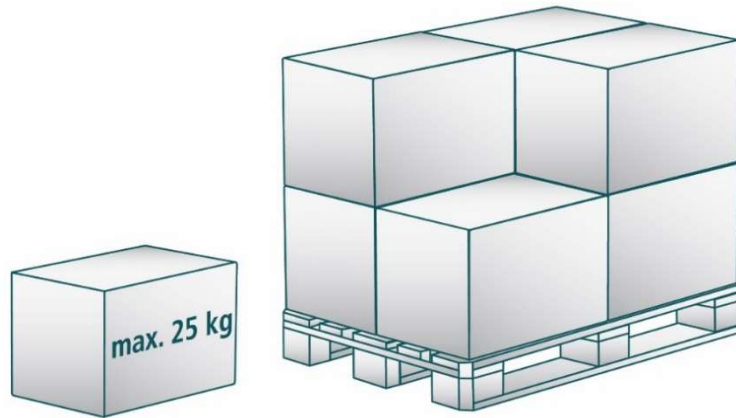

The maximum weight of a package shall not exceed 25 kg. Packages weighing more than 25 kg must be delivered on a pallet.

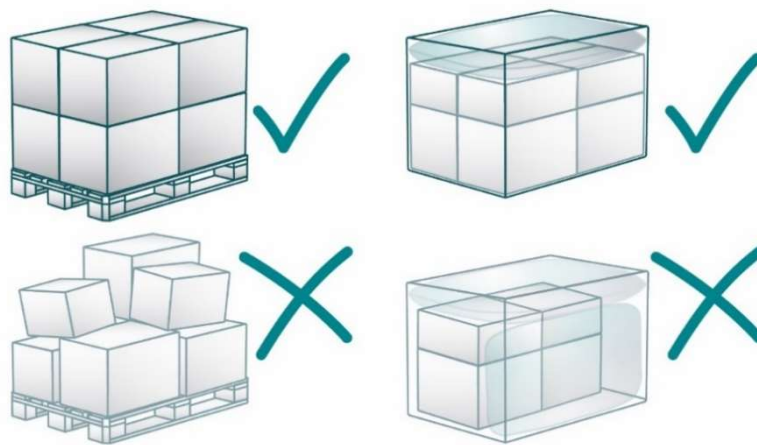

The items must be arranged within the load carrier so that the weight is uniformly distributed. The same applies to the positioning of the individual packages on the load carrier. Sensitive parts must be properly padded.

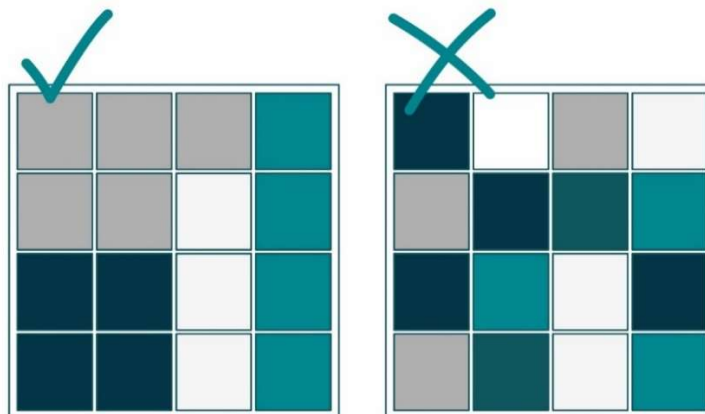

If a pallet or a package cannot be delivered sorted by type, the articles in the container must be arranged and labeled in such a way that they can be clearly identified.

## 07 Delivery Dimensions and Weights

Unless otherwise specified in the order, the following requirements apply to them.

- The total dimensions per package shall not exceed 2750x1500x1600 mm at DAP Neumünster, Germany
- The total weight of the shipment DAP Neumünster shall not exceed 1 500 kg
- Each pallet shall not exceed the weight limit of 1 500 kg

Other dimensions must be approved by Logistics of the R&M Group.

## 08 Protection

All cargo must be protected from transport damage and environmental contamination.

This rule also applies to oversized cargo and components.

## 09 Product Labeling

All parts (except small parts) and all sub-packaging shall have durable labels showing the following information as a minimum requirement:

- Description
- Order number from R&M
- Item number according to R&M order

The marking must be visible without prior repackaging.

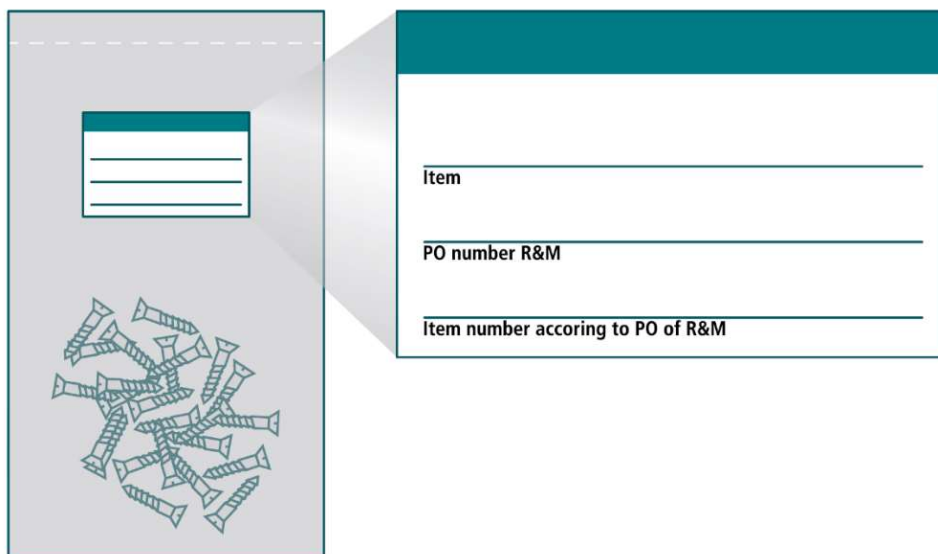

If the labeling of a part is not reasonable (technically or economically, e.g., screws), the parts must be packed in an adequate packaging container. Sample label: At least one label with the above data must be attached to the delivered parts/packages.

If further information is required in the order, it must be included accordingly.

## 10 Collective Shipment

Multiple shipments sent on the same day must be combined into a single consolidated shipment.

## 11 Packaging Material

The relevant environmental laws and regulations must be observed when selecting the packaging material. All disposable packaging must be marked with clearly visible standard symbols (in accordance with DIN 6120) or with symbols recognized by the waste industry. Markings, adhesive tape, packaging tape and signs must not impair the recyclability of the packaging.

In addition, the "Guideline for the Regulation of Wood Packaging Material in International Trade" ISPM Publication Number 15, 2002 shall be complied with.

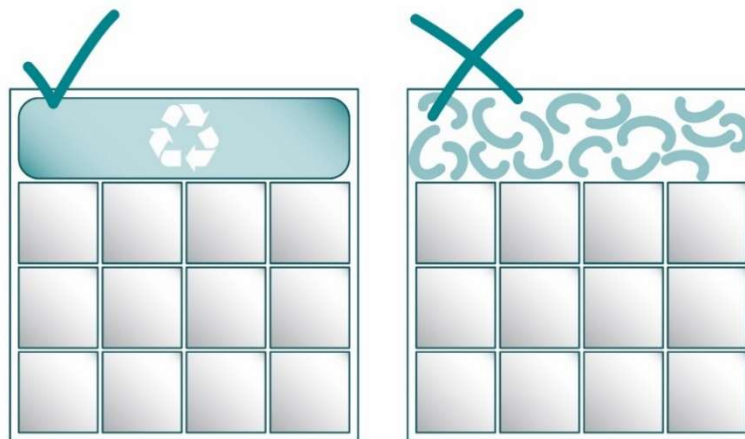

If packaging material is used, it must be easy and quick to remove and as far as possible recyclable. Loose filling material, such as packaging chips, shredded material, newsprint, wood wool, etc., should be avoided as far as possible.

In addition to the documents mentioned under 04, pictures of the shipment including the packaging and the IPPC stamp of the load carrier must be taken when the goods are ready for dispatch.

A delivery cannot be accepted without prior submission of the images confirming that the packaging and load carrier comply with the ISPM guidelines. Below are the requirements for an IPPC stamp:

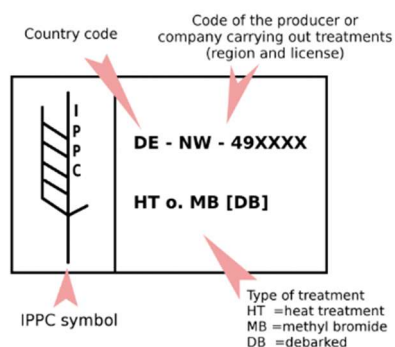

## 12 Load Mounting

If the ordered goods are stacked on a pallet, the individual goods must be secured against slipping by intermediate layers of a suitable material. All goods on the pallet must be secured with plastic or steel straps. Please ensure that any steel straps used do not cause contamination or corrosion.

Also, for each delivery, it has to be ensured that unpacking is possible using standard lifting equipment.

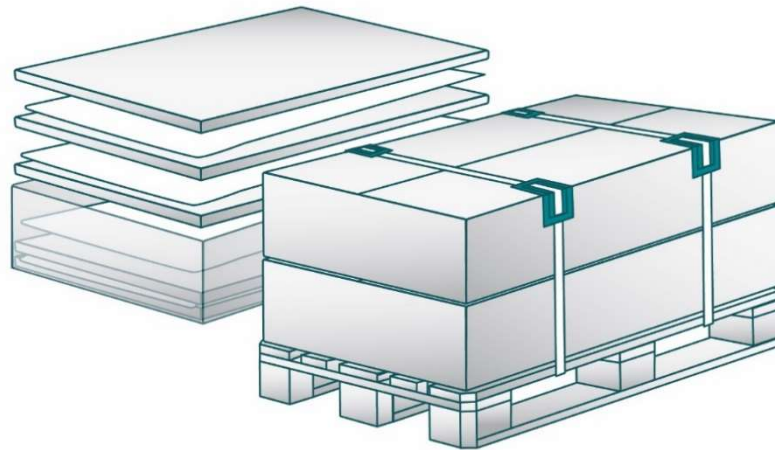

Materials must be secured against slipping with plastic or metal straps. The load securing device and the materials must be protected against damage by edge protection. (Stacked) materials must be protected against damage and slipping during transport, e.g., by intermediate layers.

## 13 Separate Protection of Goods

The use of corrosion protection products requires the approval of R&M without exception.

## 14 Product-Specific Packaging

Any instructions regarding product-specific packaging must also be considered.

## 15 Regulation of Exceptions

If there are specific packaging requirements for certain materials, these must be specified in the offer.

If these packing instructions cannot be met, R&M must be contacted before delivery.

## 16 Deviations

In the event of deviations from these conditions, R&M reserves the right to charge all additional costs incurred by R&M - such as for handling, repackaging, cleaning, washing, or labeling - or to refuse acceptance of the delivery.

## 17 Contact details of the R&M Group Logistic

### **R&M Group**

#### **(Headquarters)**

Schellerdamm 22-24

21079 Hamburg/Germany

phone +49 40 752444-0

[hg@rm-group.com](mailto:hg@rm-group.com)

[logistics@rm-group.com](mailto:logistics@rm-group.com)